

FRAME	Dimension "A"	Dimension "B"	Weight
C	21.06	12.93	255#
D	23.56	15.43	305#
F	24.38	16.25	320#
DL	27.69	19.56	385#

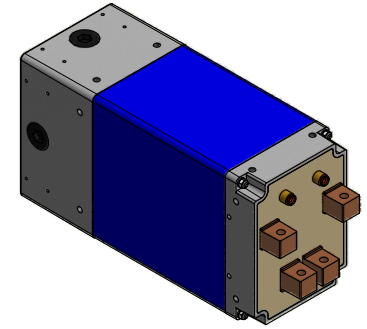

WATER FLOW 1 GPM MIN. @ 30°C (86°F)

Water Connection 1/4-18 NPT - 2 Places

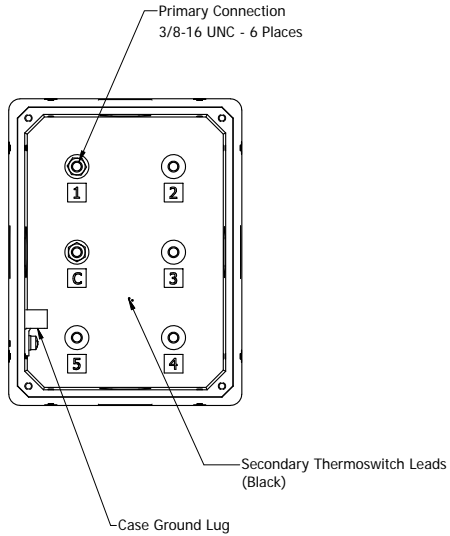
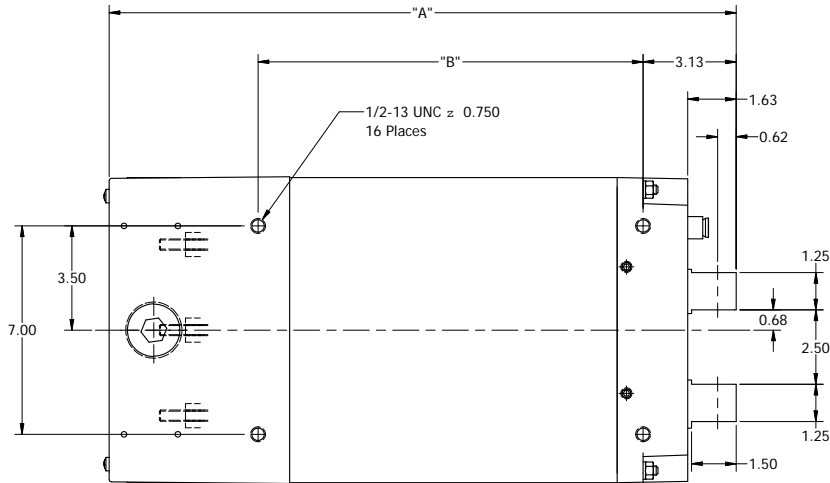
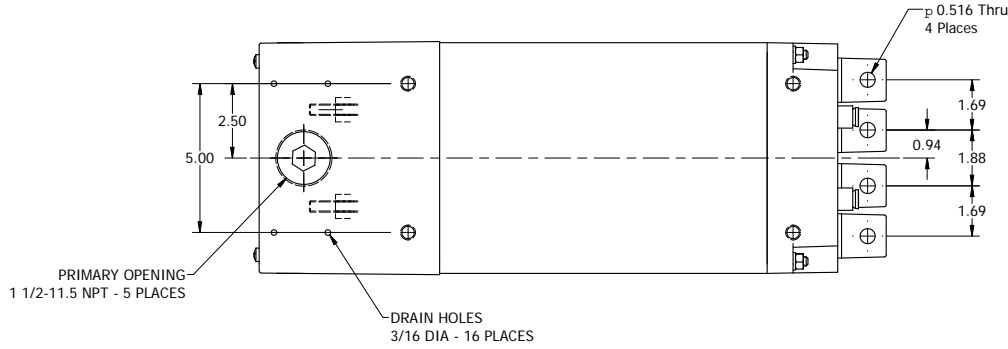
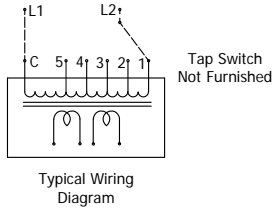
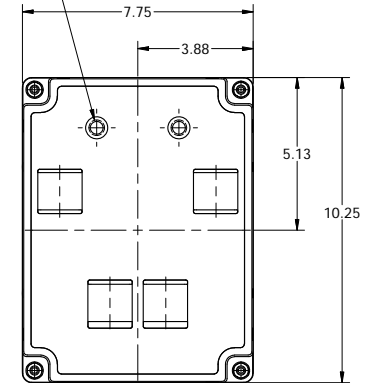

REV	DESCRIPTION	DATE
B	ADDED WIRING DIAGRAM	10/17/2012
A	MOVED LOCATION OF THERMOSWITCH LEADS	10/8/2012

THIS DRAWING AND ALL THE INFORMATION AND TECHNOLOGY IS IT AND EXCLUSIVE, CONFIDENTIAL AND PROPRIETARY TO RADIANT. THIS INFORMATION IS NOT TO BE REPRODUCED OR TRANSMITTED IN ANY FORM OR BY ANY MEANS, ELECTRONIC OR MECHANICAL, INCLUDING PHOTOCOPYING, RECORDING, OR BY ANY INFORMATION STORAGE AND RETRIEVAL SYSTEM. THIS DRAWING AND SHALL BE USED ONLY FOR THE LIMITED PURPOSE FOR WHICH IT IS SPECIFIED AND ONLY TO THE EXTENT OF SUCH USE. ANY OTHER USE, REPRODUCTION OR TRANSMISSION IS STRICTLY PROHIBITED.	DRAWN BY: rbowerman APPROVED: N/A
SCALE: None DATE: 7/5/2012	
Transformer	
	DRAWING NUMBER: R4503 RWMA STAGGERED - C,D,F,DL